

CAUTION! Installation and connection should only be carried out by a qualified person and in accordance with national wiring regulations.

- Before commencing any work on the electrical connections, you must first disconnect the programmer from the mains. None of the 230V connections must be live until the installation has been completed and the housing is closed. Only qualified electricians or authorised service staff are permitted to open the programmer. Disconnect from mains supply in the event of any damage to any buttons.
- There are parts that carry mains voltage behind the cover. The programmer must not be left unsupervised when open. (Prevent non specialists and especially children from gaining access to it.)
- If the programmer is used in a way not specified by the manufacturer, its safety may be impaired.
- Prior to setting the timeswitch, it is necessary to complete all required settings described in this section.
- Never remove this product from the electrical baseplate. Do not use sharp tools to push any button.



Important: Keep this document

This 4 zone programmer is designed to provide ON/OFF control for 4 zones, with the value added application of in built frost protection and keypad lock.



This programmer can be mounted in the following ways: 1. Directly wall mounted 2. Mounted to a recessed conduit box

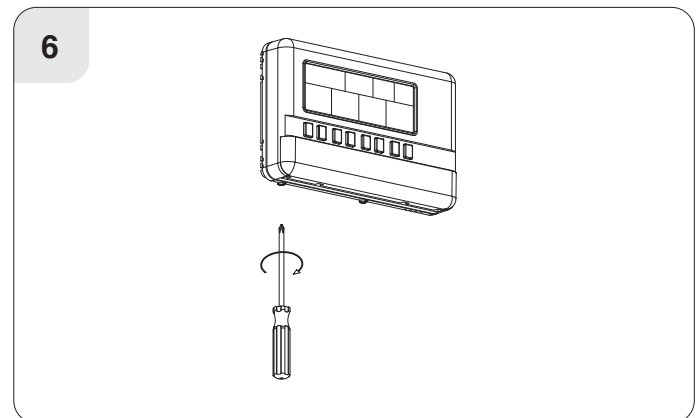
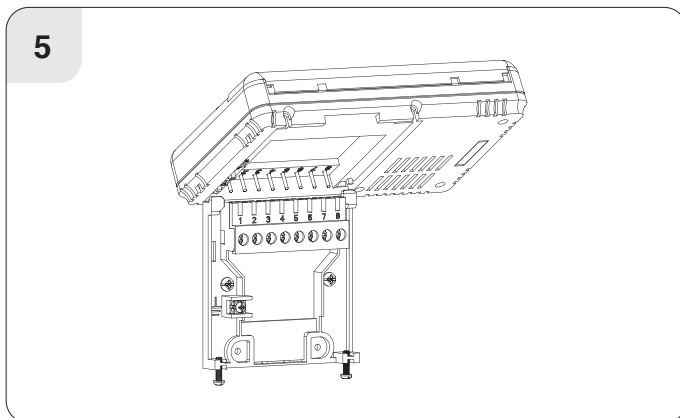
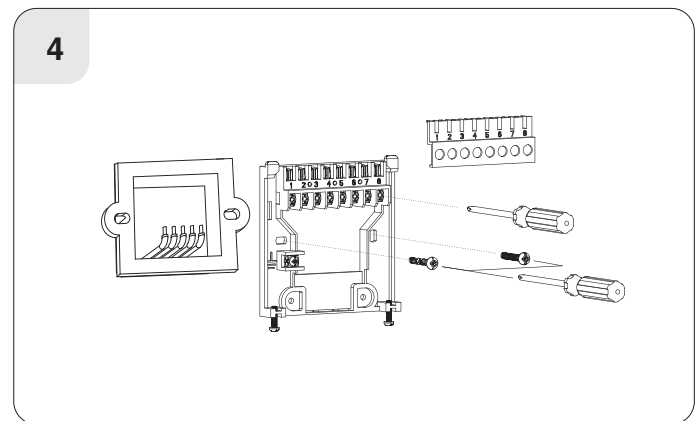
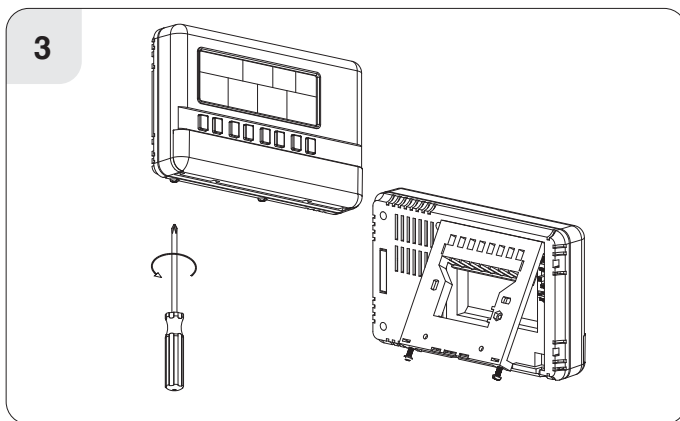
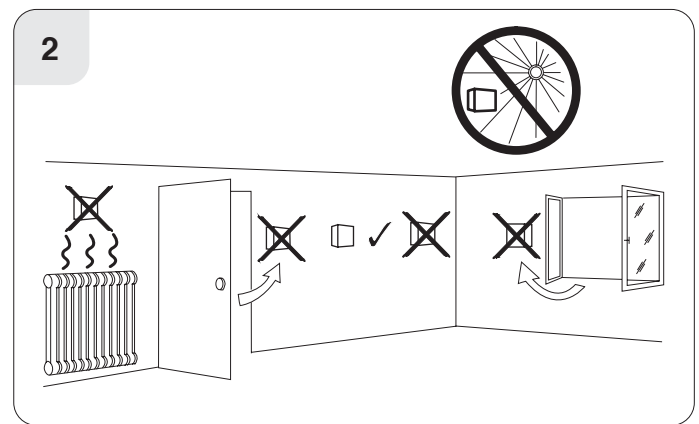
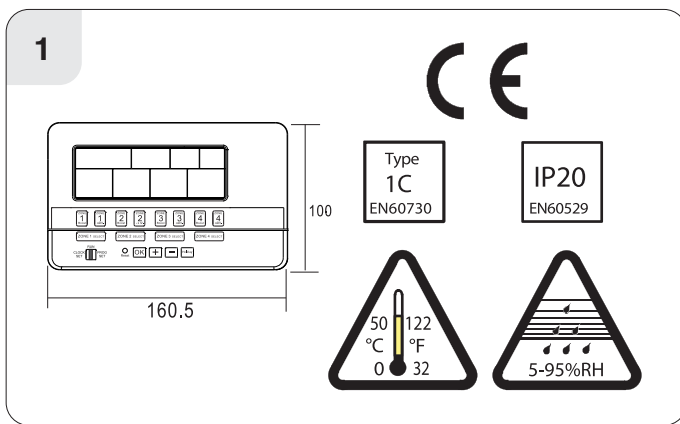

20170313_AW1077_R47_InsIns_JW



EPH Controls Ireland
 Sitecast Industrial Estate, Pouladuff,
 Cork, T12 W665, Ireland
sales@ephcontrols.com www.ephcontrols.com

EPH Controls UK
 Unit E4, Welland Business Park, Valley Way, Market Harbo
 Leicestershire, LE16 7PS, United Kingdom
sales@ephcontrols.co.uk www.ephcontrols.co.uk

Visit **Plumb2u**

See product

Contents

1. Factory default settings
2. Specifications & wiring
3. Master reset



1. Factory default settings



| | |
|-------------------|------------------|
| Contacts: | 230 Vac contacts |
| Program: | 5/2D |
| Backlight: | On |
| Keypad: | Unlocked |
| Frost Protection: | Off |
| Clock type: | 24 Hr Clock |
| Day-Light Saving | |

2. Specifications & wiring

| | |
|------------------------|---|
| Power Supply: | 230 Vac |
| Ambient Temp: | 0~35°C |
| Contact Rating: | 250 Vac 3A(1A) |
| Program Memory backup: | 1 year |
| Battery: | 3Vdc Lithium LIR 2032 |
| Backlight: | Blue |
| IP rating: | IP20 |
| Backplate: | British System Standard |
| Pollution degree 2: | Resistance to voltage surge 2000V as per EN 60730 |

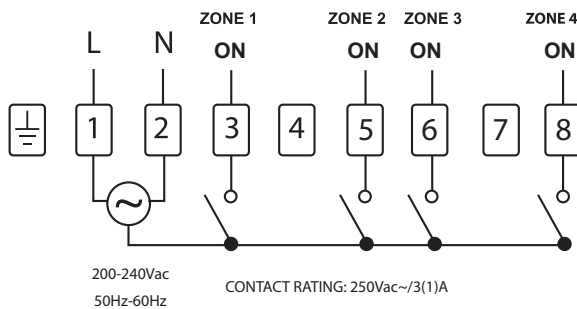

3. Master reset

Lower the cover on the front of the programmer. There are four hinges holding the cover in place.

Between the 3rd and 4th hinges there is a circular hole. Insert a ball point pen or similar object to master reset the programmer.

After pressing the master reset button, the date and time will now need to be reprogrammed.